

LIGHTING PRODUCTS

FIRE RESEARCH CORPORATION
26 Southern Blvd., Nesconset, NY 11767
TEL 631.724.8888 FAX 631.360.9727
TOLL FREE 1.800.645.0074
www.fireresearch.com

VantagePoint

MODEL LED400 SERIES

XE-LED400-A06-B (Black) or XE-LED400-A06-W (White)

SAFETY SUMMARY

FRC lighting products are engineered and manufactured with safety in mind. It is critical that FRC lights are installed, maintained, and operated correctly. Read and understand all instructions before installing, performing maintenance, or operating.

All components, equipment, and installation procedures shall conform to NFPA 1901, *Standard for Automotive Fire Apparatus* and NFPA 70 *National Electrical Code*.



General Safety Precautions

Do not stare directly at LEDs when power is on. Ensure power is off prior to connecting or disconnecting wires/cables and plugs to a power source or performing maintenance. Disconnect ground connection from battery marked '-' to avoid accidental short circuits before attempting to connect electrical wires.

Installation Safety Precautions

Connect the LED light to a 12 or 24 volt DC power source. Ensure an appropriate sized circuit protection device is installed (circuit breaker or fuse). See Specifications below.

DESCRIPTION:

The Vantage Point light is a rotatable, remote-controlled LED light. The wireless remote allows the light to be remotely adjusted by the operator. It has a vertical tilt up of 70° and 45° tilt down (diagram on page 2.) Horizontal rotational range is infinite (clockwise and *counterclockwise*). This allows for a pan-tilt motion.

Also equipped with a flashing alert feature, which can be used to warn approaching motorists or pedestrians of potential hazards or help is needed. It can also be used with service vehicles to alert the on-coming vehicles there are people at work, and more.

Stow Feature: with DC power on and connected, the light will automatically resume to the forward facing position after turning it 'OFF'. If power is shut down from the apparatus while the light is still 'ON', the light will resume to the forward facing position after it is turned back 'ON'. The light has 16 LEDs. Available with a black or white housing.

SPECIFICATIONS:

1. Operating Voltage: 10 - 30VDC
2. Power Consumption: 80W
3. Maximum Distance for Operating Remote Control: Up to 130 ft.
4. Weight: 7 lbs. (3.2KG)
5. Remote Control Battery: (1) A23 battery (12V)



(2) Remote Controls Supplied

REMOTE CONTROL KEYPAD OPERATION:

The remote control is used to control the operation of this light and features six (6) buttons in total. The ON/OFF button (bottom left button) will illuminate the LEDs or shut them off. The direction of the light is controlled by the arrow buttons: pan/tilt by pressing the up, down, left and right arrow buttons. The bottom right button with the "F" controls the Warning/Flash pattern light beam.

1. ON/OFF—Press the ON/OFF to power the light on or off. When the light is OFF, this disables all button functioning.
2. Up Arrow—Press and hold the UP arrow to raise the light beam; the light will rotate upward to a maximum of 70°.
3. Down Arrow—Press and hold the DOWN arrow to lower the light beam; the light will rotate downward to a maximum of 45°.
4. Left Arrow—Press and hold the LEFT arrow to pan left.
5. Right Arrow—Press and hold the RIGHT arrow to pan right.
6. Warning Signal—Flashing LED (Flashes 3 long, 3 short). The light will flash 6 times in 1 minute, and repeats every 6 to 8 seconds. To disable warning signal, press it again and the light returns to normal function.

REMOTE CONTROL PAIRING:

The default state for the light is to be unpaired to any remote control. However, the light can be paired to any remote control, and it is open to being paired to any remote control. To avoid interference from other remote control devices that are within range, it is highly recommended to pair the light to a remote control. (*2 remote controls are supplied with each light.*)

Pairing Steps:

1. Turn the light 'ON' by pressing the 'ON/OFF' button. *Within 1 minute**, the light can be paired with any remote by pressing and holding the 'ON/OFF' button on a remote control for 6 seconds. (For this example, this is referred to remote #1.) Once remote #1 is paired to the light, the light will flash 3 times (as 3 long flashes) and then the light will turn off. Pairing is complete.
2. Remote #2 can be paired as instructed in step 1.
3. **Only 2 remotes can be paired to each light.** If a third remote is paired to the same light, the first remote will get unpaired from this light.

***NOTE:** The pairing or unpairing process will timeout after 1 minute of inactivity.

Unpairing Steps:

Removing pairing means that the light will not be paired to any previously paired remote controls, and can be controlled by any unpaired remote within operating distance. This is the default mode for the light.

1. The remote can be unpaired whether the light is 'ON' or 'OFF'.
2. *Within 1 minute** of turning the light 'ON' or 'OFF', press and hold the 'ON/OFF' button on the remote for 6 seconds.
3. The light's LEDs will flash for as 3 short flashes and then the light will turn 'OFF'.
4. The light is now unpaired from the remote and will reset to the default mode (as mentioned above).

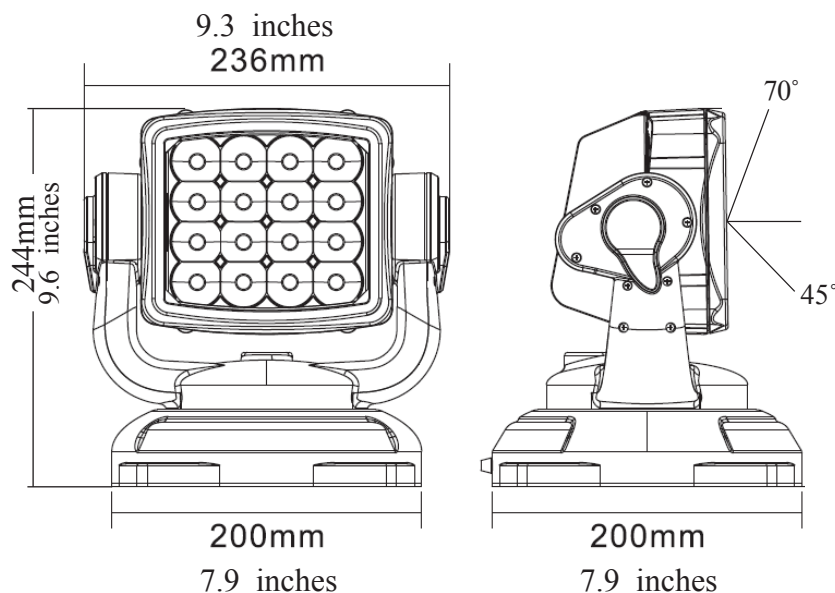
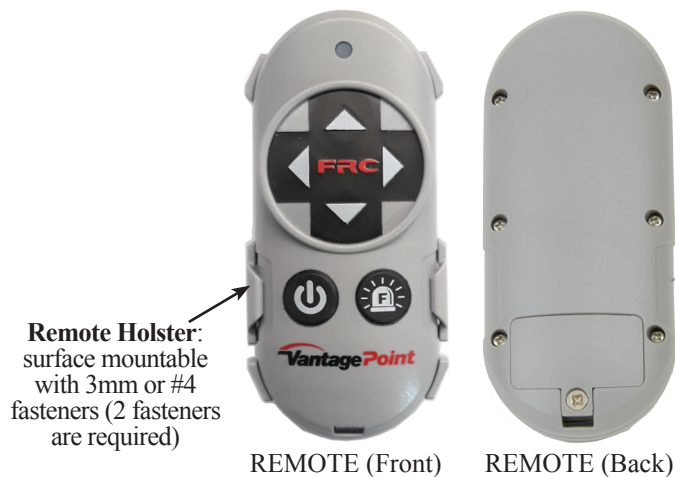

MAINTENANCE

Use a clean soft cloth, mild soap, and water to clean the lens.

NOTE: FRC LED lampheads use Lexan lenses and cleaning with abrasive materials, solvents, or most chemical cleaners can cause lens surface degradation and reduced performance of the light. ***Some chemicals will cause the lens to become brittle and prone to cracking.***